



**Dual Redundant  
Controllers!**

## High Performance RAID 6 Storage

# JetStor SAS 616F

Continuing AC&NC's long track record of cost-efficient, feature-rich mid-range storage solutions, the affordable JetStor SAS 616F provides the optimal solution for your applications requiring high-performance, high-availability, easy deployment, administration, and on-line expansion.

The JetStor SAS 616F 16 bay RAID system delivers up to 1,200 MB/s read and 760 MB/s write access to up to 64 terabytes of storage to support your most demanding applications. A fifth-generation RAID controller architecture utilizes the PowerPC 440SPe RISC storage processor to achieve unprecedented peak performance of 10.4 GB/sec internal bandwidth per controller. Two or four redundant 4 Gb/s Fibre Channel ports provide instantaneous access to your data, complete with automatic fail-over.

### ADVANCED DATA PROTECTION

Designed for mission critical applications, the JetStor SAS 616F's protects your data with:

- Redundant and hot-swappable active/active RAID controllers with shared cache
- Redundant flash image to protect configurations
- Redundant and hot-swappable power supplies, cooling blowers and air re-directors
- Redundant and automatic MPIO fail-over Fibre Channel ports
- Proactive event monitoring software
- On-line RAID set integrity verification
- A cableless design with a single backplane
- An embedded SMTP client for email notification
- An embedded SNMP agent for external monitoring applications
- An optional SES2 module for direct, in-band SCSI enclosure management.

Most importantly, the JetStor SAS 616F provides RAID 6 with ADS (Advanced Data Sentry) — over 1,000 times the data protection provided by RAID 5.

### ✓ Compact Enclosure

- Up to 16 TB in 3U
- Expandable to 64 TB in 12U
- Sixteen SAS bays

### ✓ High Availability

- Dual redundant/failover active/active hot-swappable RAID controllers
- Dual redundant/failover hot-swappable cooling with automatic airflow re-directors
- Dual/quad redundant/failover MPIO Fibre Channel ports
- RAID 6 survives two simultaneous drive failures
- Instant availability with background RAID set initialization

### ✓ High Performance

- 10.4 GB/sec peak internal bandwidth
- Two to four 4Gb/s Fibre Channel ports

### ✓ Outstanding Warranty

- Five years on disk drives and three years on all other components.
- Optional advanced replacement program ships drive replacements within 24 hours. Optional on-site service also available.
- Free telephone and email support provided for the life of the unit

## State-of-the-art RAID 6 data protection

The JetStor SAS 616F's RAID 6 with ADS provides the highest level of data protection by tolerating multiple simultaneous drive failures without downtime or data loss. The JetStor SAS 616F's probability of data loss is 1/1,000 (three orders of magnitude) less than that of an equivalent RAID 5 array.

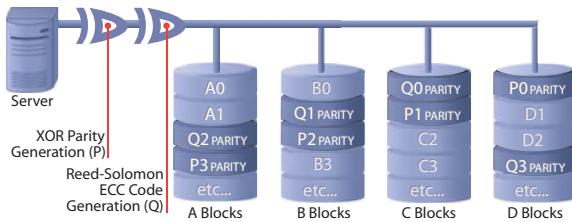

RAID 6 stores two parity blocks per stripe

Where RAID 5 writes one parity block for each stripe across the array, RAID 6 with ADS saves two parity blocks, allowing the JetStor SAS 616F to continue operating with two inoperative drives, without the loss of data or availability.

As drive sizes have increased, the time required to rebuild an inoperative drive's data has stretched to several hours. During a rebuild, data on the remaining drives within a RAID 5 array is unprotected. Should a second drive fail, the rebuild will halt, and the entire RAID set may be lost. Because RAID 6 with ADS tolerates two simultaneous drive failures, your data remains fully protected during the rebuild process.

RAID set verification may be run ad-hoc or scheduled to test every sector for proactive error detection. Furthermore, the system constantly monitors drive health to proactively predict failure, and to automatically copy data to a spare drive before the drive fails.

## Easily expands for future demands

The JetStor SAS 616F RAID system supports up to 16 TB within its enclosure, and is further expandable with up to three 16 bay SAS JBOD cabinets, for a total of 64 TB of high-performance, high-availability storage.

The JetStor SAS 616F provides you the choice of high-performance SAS drives to optimally meet your application's requirements.

Expansion cabinets are interconnected by two high-speed SAS cables, directly extending the system's backplane. The optional SCSI Enclosure Services (SES) interface further monitors all connected JBOD expansion cabinets without additional cabling.

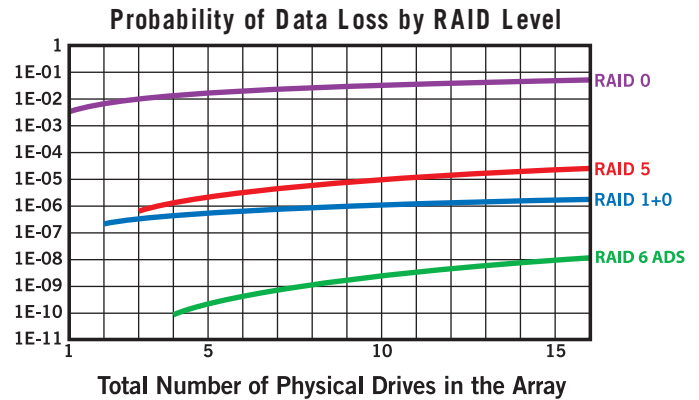

### RAID Specific Features

- Supports RAID levels 0, 1, 0+1, 3, 5, and 6 with ADS
- Up to 64 array groups
- Up to 1024 LUNs
- Online and automatic RAID expansion
- Hot spares designated global or local to one RAID set
- Array roaming simplifies moving RAID drives between cabinets
- Immediate RAID availability (background RAID set initialization)
- Cache policy management for fine-tuned performance
- Online and automatic background rebuild of replacement drives
- Proactive disk failure monitoring and preemptive replacement drive cloning
- Variable stripe size for application-specific tuning
- Dual active-active controller redundancy with mirrored cache
- RAID 6 hardware acceleration integrated within the PowerPC RISC processor for maximum performance

Drives	300GB SAS	1TB SAS	64 drives in 12U One JetStor 616F RAID 6 system and three JBOD cabinets
64	19.2TB	64TB	
48	14.4TB	48TB	
32	9.6TB	32TB	
16	4.8TB	16TB	

## Reliable, fault-tolerant design

The JetStor SAS 616F provides complete redundancy of all system components for non-stop, high-availability access to your data. Should any component report an error, its counterpart immediately takes over without interruption. All components may be hot-swapped while the system is on-line and operational. All redundant components are active individually, each contributing to system performance (active/active rather than active/standby).

All components plug directly into the JetStor SAS 616F's backplane utilizing the highest quality industry standard SAS connectors to ensure transfer speed and reliability. This simple design eliminates all cabling points of failure. All components are field-replaceable by untrained office personnel.

Each redundant component is engineered to maintain full system performance in the event of a component failure. Should a RAID controller fail, all virtual connections automatically MPIO failover to the remaining controller without interruption or data loss, continuing service with 800 MB/s access. Dual power supplies are individually capable of powering a fully populated cabinet indefinitely. The JetStor SAS 616F's 600 watt power supplies provide excess power to support future drive demands.

Innovative air flow management technologies include two dedicated intra-chassis fans to automatically redirect air within the cabinet to balance interior temperatures, forwarding airflow to the failed blower towards its counterpart. Each blower is capable of sufficiently cooling a fully populated cabinet indefinitely. This unique temperature management ensures every component maintains a consistent low temperature for the longest possible life.

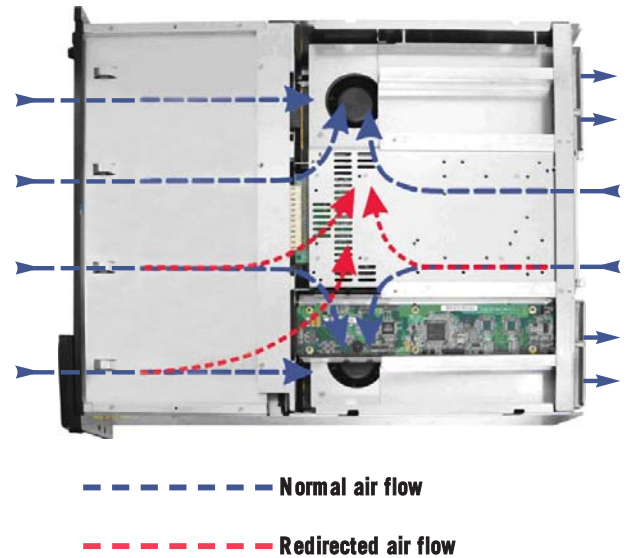
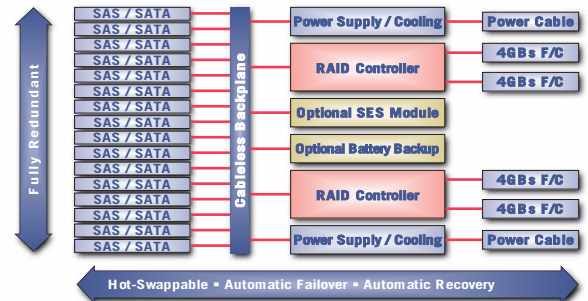

## Easily managed over your network

The Jetstor RAID Manager configuration and monitoring software allows you to remotely manage all JetStor systems over your network. An integrated SMTP client delivers e-mail to the appropriate designated personnel of all significant events, including proactive detection of failing drives.

An optional SCSI Enclosure Services (SES version 2) interface allows server based management software to monitor the cabinet, cooling blowers and power supplies directly through the SCSI/Fibre Channel connections, eliminating the requirement for a separate Ethernet path to the server or RS-232 cabling. SNMP (Simple Network Management Protocol) support allows the JetStor SAS 616F to be monitored by enterprise-wide infrastructure management applications.



The JetStor RAID Manager provides easy configuration, management and monitoring of all JetStor systems



## Specifications



**JetStor SAS 616F**

Number of bays / size	16 bay / 3U
Maximum expansion capacity	64 bays / 12U
Storage capacity <sup>1</sup>	16TB SAS
Maximum storage capacity <sup>1</sup>	64TB SAS
RAID level support	0,1,10,5 and <b>6 with ADS</b>
RAID processor(s)	PowerPC 440SPe RISC storage processor, embedded XOR engine
Backplane interface	PCI express X4
Disk backplane interface	Sixteen dual-ported 3Gb SAS channels
Fibre Channel interface	Two, 4Gbit/sec Optical SFP LC ports per RAID controller
Cache (ECC supported)	1-2 GB per RAID controller (One 667 MHz DDR2)
Management ports	RJ45 Ethernet
Power supplies (Hot-swappable)	Two redundant 600W Two power Connections
Cooling blowers (Hot-swappable)	Dual redundant Dual re-director fans
Battery backup	Optional, 72 hour
Controller WHQL (Windows Hardware Quality Labs) Certified	

## Warranty and support

Five years on disk drives and three years on all other components. Optional advanced replacement program ships drive replacements within 24 hours. Optional on-site service also available. Free telephone and email support provided for the life of the unit.

## Operating system s

Windows Server 2003, Windows Server 2008, Windows 2000 & MSCS (Microsoft Cluster Server), VMware ESX, MAC OS X, Sun/Solaris, Linux

<sup>1</sup>Maximum storage capacities are calculated with 1TB SAS drives. Drive support not limited to drive capacities listed, all future drive capacities supported when available.

All features, hardware and software performance specifications are subject to change without notice.

## Hot-swappable drive trays



Ergonomically designed drive trays allow for safe on-line replacement or expansion with SAS disk drives.

## Convenient rear panel access

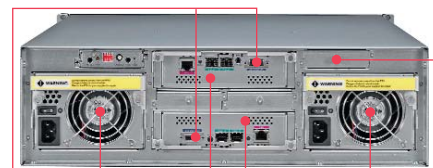

Redundant, hot-swappable RAID controllers, each with two 4Gb F/C and one Ethernet port

Redundant, hot-swappable power supplies with integrated cooling and two power connections

Optional battery module keeps data online through power interruptions

Redundant expansion ports allow for up to four cabinets with 64 drives

## Convenient front panel control



Front panel display and controls display the status of the system, power supplies, fans and drives, with an audio event alarm.